

➤ Tangential-flow hollow cone nozzles Series 350

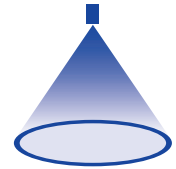

Features:

- High performance nozzle for humidification of air
- Very narrow droplet spectrum
- Extremely uniform liquid distribution over the entire spray pattern
- Quick-release clamp unit available for pipe mounting

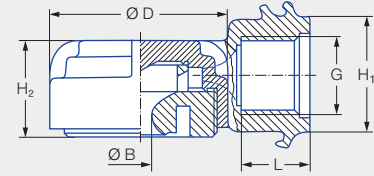
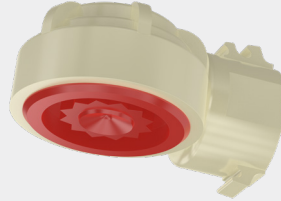

Applications:

- Foam control
- Dust control
- Surface spraying
- Absorption

Series 350

| G | Dimensions [mm] | | | | Weight [g] | P _{max} [bar] |
|----------|-----------------|----------------|------|------|------------|------------------------|
| | H ₁ | H ₂ | L | Ø D | | |
| 3/8 BSPP | 24.0 | 20.0 | 14.0 | 37.0 | 37.0 | 20.0 |

| Spray angle | Ordering no. | | Bore diameter B [mm] | Narrowest free cross section Ø [mm] | V̇ water [l/min] | | | | | | | Spray diameter D [mm] (at p = 2 bar) | |
|-------------|--------------|----------|----------------------|-------------------------------------|------------------|------|-------------|------|------|------|------|---|-------|
| | Type | Mat. no. | | | p [bar] | | | | | | |  H = 250 [mm] H = 500 [mm] | |
| | | 56 | | | 0.5 | 1.0 | 2.0 | 3.0 | 5.0 | 7.0 | 10.0 | | |
| 130° | 350.368 | ● | 1.55 | 0.70 | 0.32 | 0.45 | 0.63 | 0.77 | 1.00 | 1.18 | 1.41 | 950 | 1,250 |
| | 350.608 | ● | 5.00 | 1.40 | 1.58 | 2.23 | 3.15 | 3.86 | 4.98 | 5.89 | 7.04 | 990 | 1,950 |

Accessories:

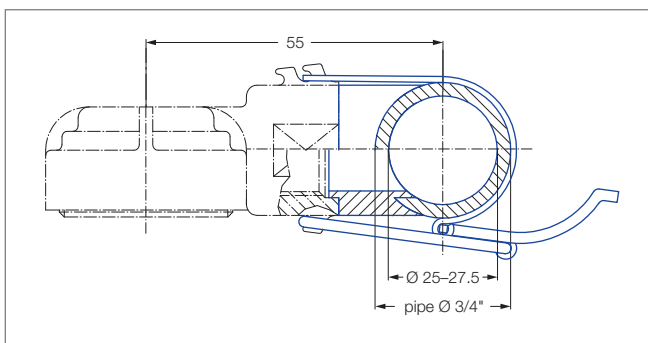

Recommended bore diameter 18 mm.

Quick-release clamp unit: Ordering no. 035.030.15.05.00.0.

Consisting of: Stainless steel clamp, polyurethane gasket.

Conversion formula for this series: $\dot{V}_2 = \dot{V}_1 \cdot \sqrt{\frac{p_2}{p_1}}$

Ordering Type + Material no. = Ordering no.
example: 350.368 + 56 = 350.368.56

 Assembly accessories can be found in Chapter 9 "Accessories".